

Atlas Copco

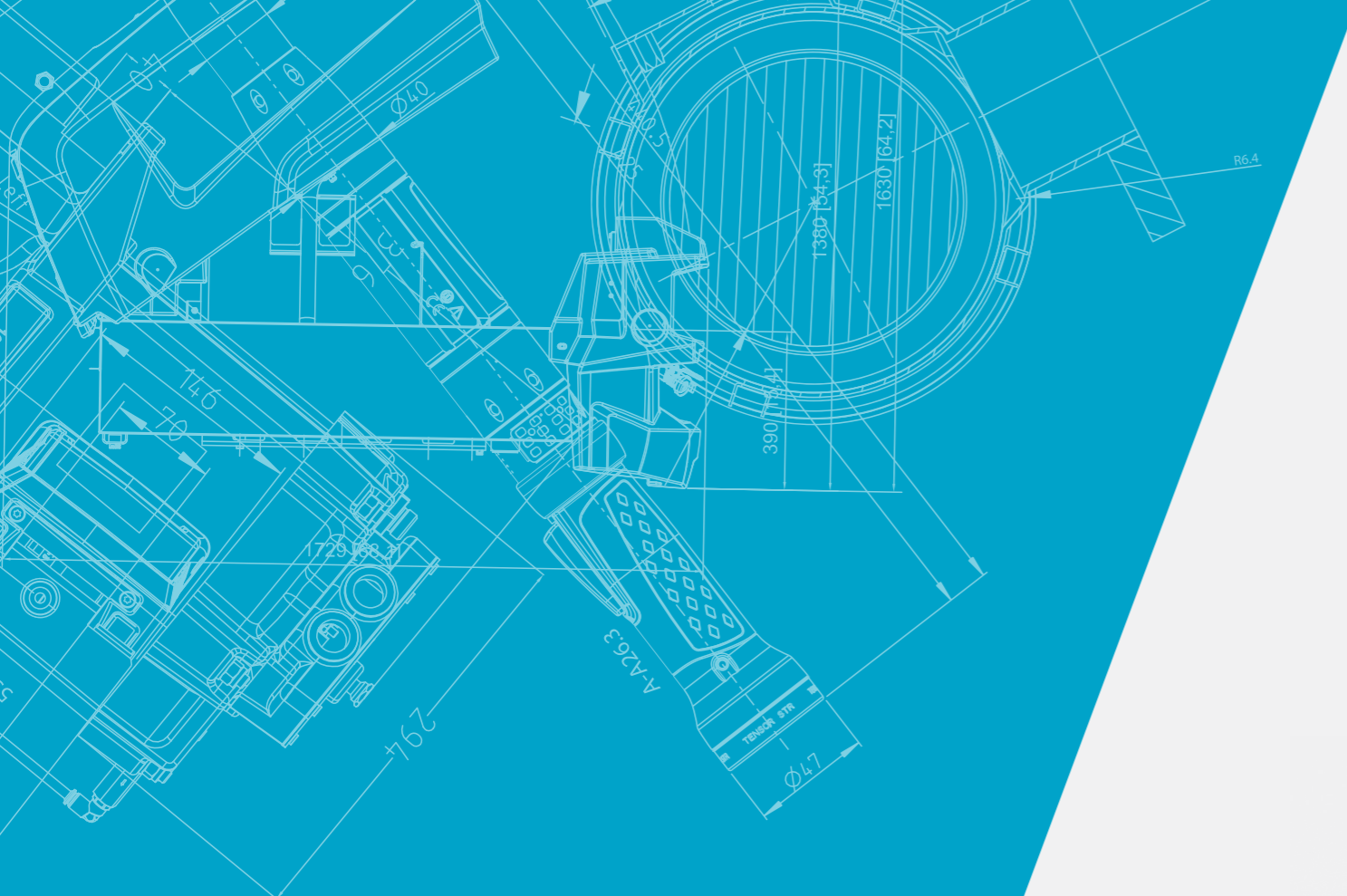

GVD 045-085

Oil-sealed double-stage
rotary vane vacuum pumps



GVD 045/065/085

Atlas Copco's latest generation of oil-sealed double-stage rotary vane vacuum pumps - the GVD 045-085 series offer high reliability and low maintenance with reduced life cycle cost. Delivering excellent ultimate vacuum pressure, high pumping speeds and superior vapor handling capabilities with quiet operation.



Improved performance

- High pumping speed
- Improved vapor handling capability ideal for humid applications
- Low noise levels



Efficiency and flexibility

- Wide range voltage IE4 motors
- Pump systemization options available
- More size variants available

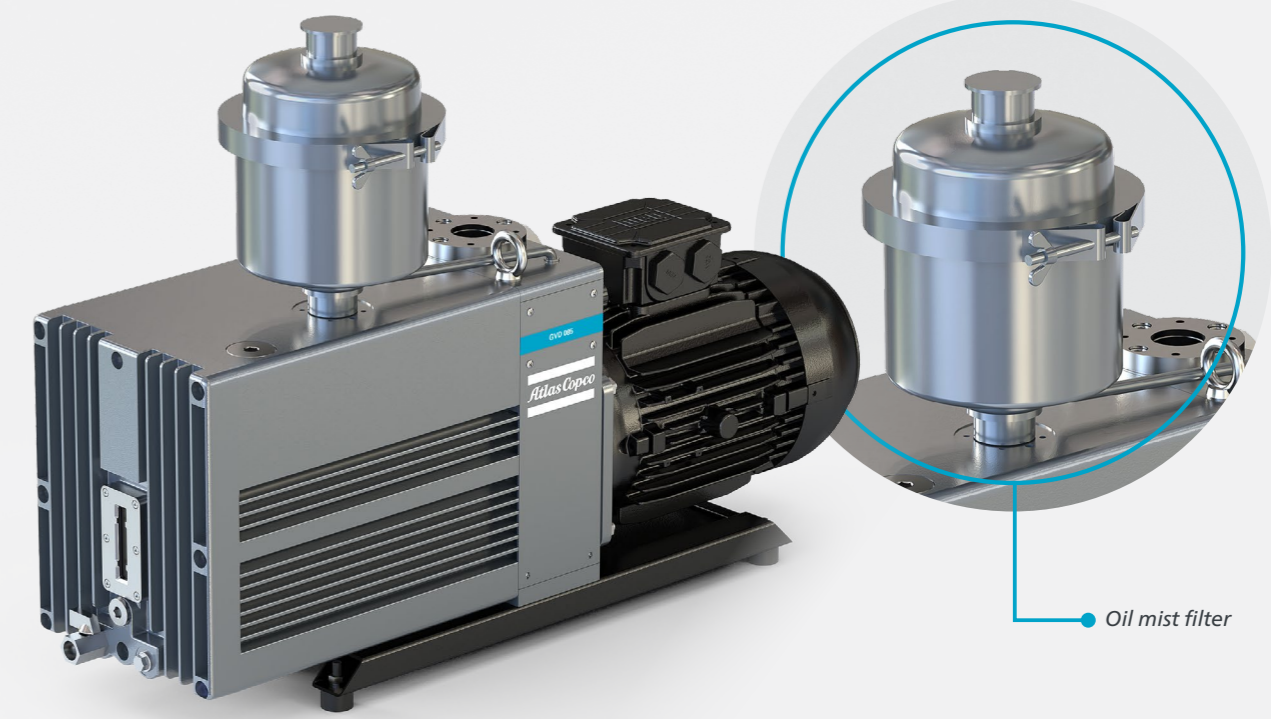

Oil mist filter



Robust and reliable pump design

- Built-in oil filter to prevent contaminants
- Improved performance for high vapor tolerance
- Plug and play with adjustable outlet flange and roots adapter



Reduced total cost of ownership

- Low power consumption
- Exhaust filter with oil return available
- Economical solution and simplified serviceability

Applications



- Freeze drying
- Coating system
- Systems & machinery
- Leak testing systems
- RAC refrigeration
- Energy technology
- Industrial furnaces
- Industrial gases
- Automotive
- Aviation
- Sterilization
- Plasma treatments



Technical specifications

	Unit	GVD 045	GVD 065	GVD 085
Nominal pumping speed (50Hz / 60Hz)	m ³ /h	49 / 59	67 / 80	92 / 110
Pumping speed (50Hz / 60Hz)	m ³ /h	42 / 50	60 / 72	79 / 95
Ultimate total pressure without gas ballast	mbar	3 × 10 ⁻³	3 × 10 ⁻³	3 × 10 ⁻³
Ultimate total pressure with gas ballast position 1	mbar	6 × 10 ⁻³	6 × 10 ⁻³	6 × 10 ⁻³
Ultimate total pressure with gas ballast position 2	mbar	2 × 10 ⁻²	2 × 10 ⁻²	2 × 10 ⁻²
Water vapor tolerance	mbar	35	30	25
Water vapor capacity 50Hz / 60Hz	g/h	1090 / 1308	1334 / 1601	1464 / 1757
Oil filling, min / max	l	3.3 / 4.3	3.5 / 4.5	3.8 / 4.8
Admissible ambient temperature	°C	10 ~ 40	10 ~ 40	10 ~ 40
Noise level without / with gas ballast position 1	dB(A)	58 / 60	58 / 60	58 / 60
Motor rating power (50Hz / 60Hz)	kW	1.1 / 1.3	1.5 / 1.8	2.2 / 2.6
Nominal speed	rpm	1465	1456	1472
Type of protection	IP	55	55	55
Intake connection	DN	40 KF	40 KF	40 KF
Exhaust connection	DN	25 KF	25 KF	25 KF
Pump dimensions (L x W x H)	mm	785 x 244 x 405	815 x 244 x 405	902 x 244 x 405
Shipping dimensions (L x W x H)	mm	984 x 314 x 574	984 x 314 x 574	984 x 314 x 574
Net weight	kg	87	92	117
Total shipping weight	kg	100	105	131

Performance curves

Pumping speed

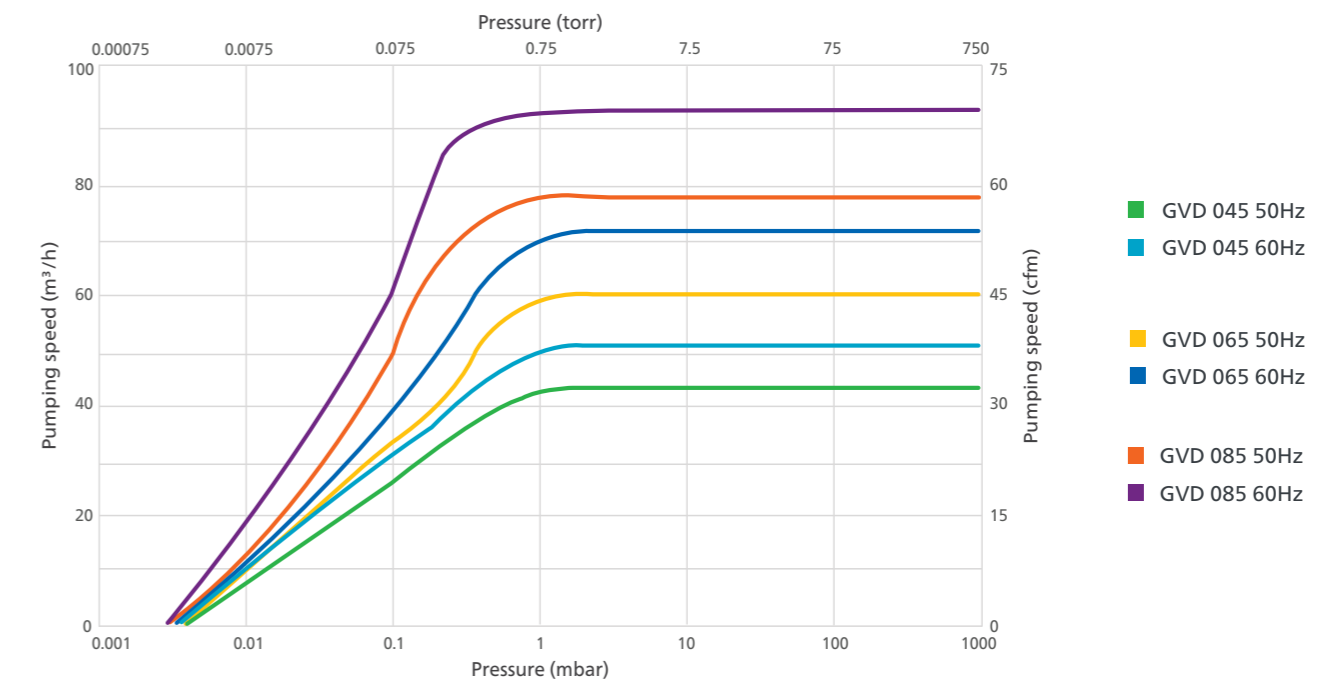

Technical drawings

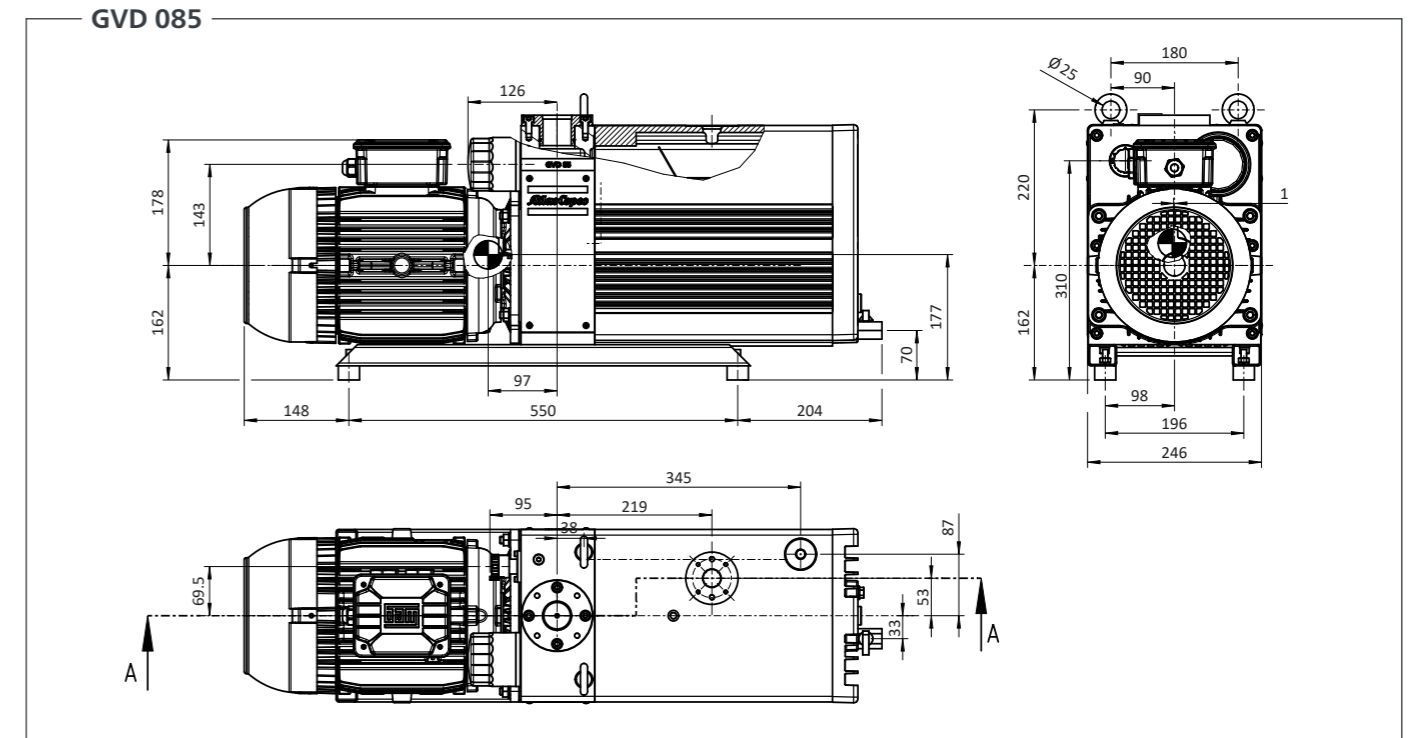
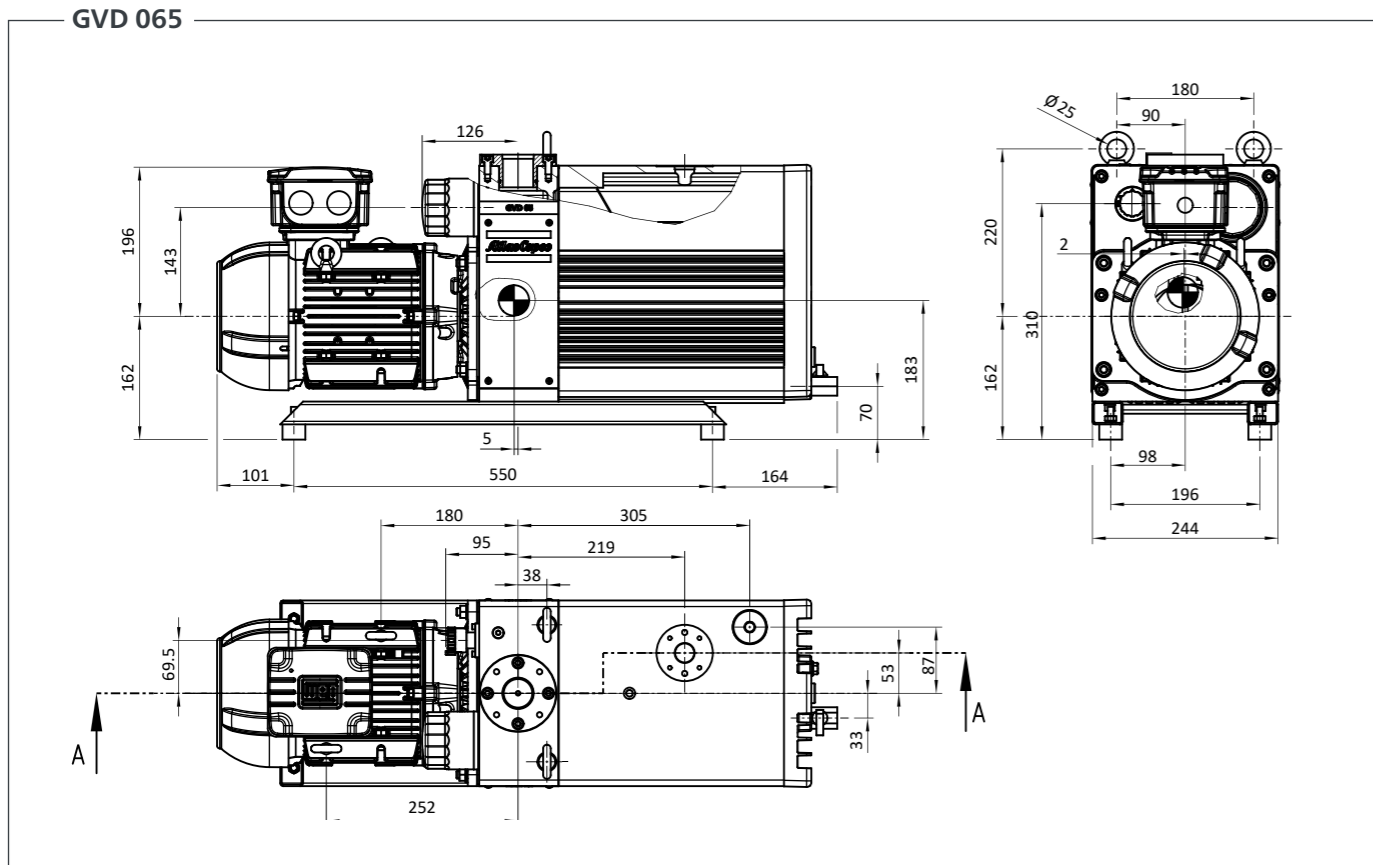
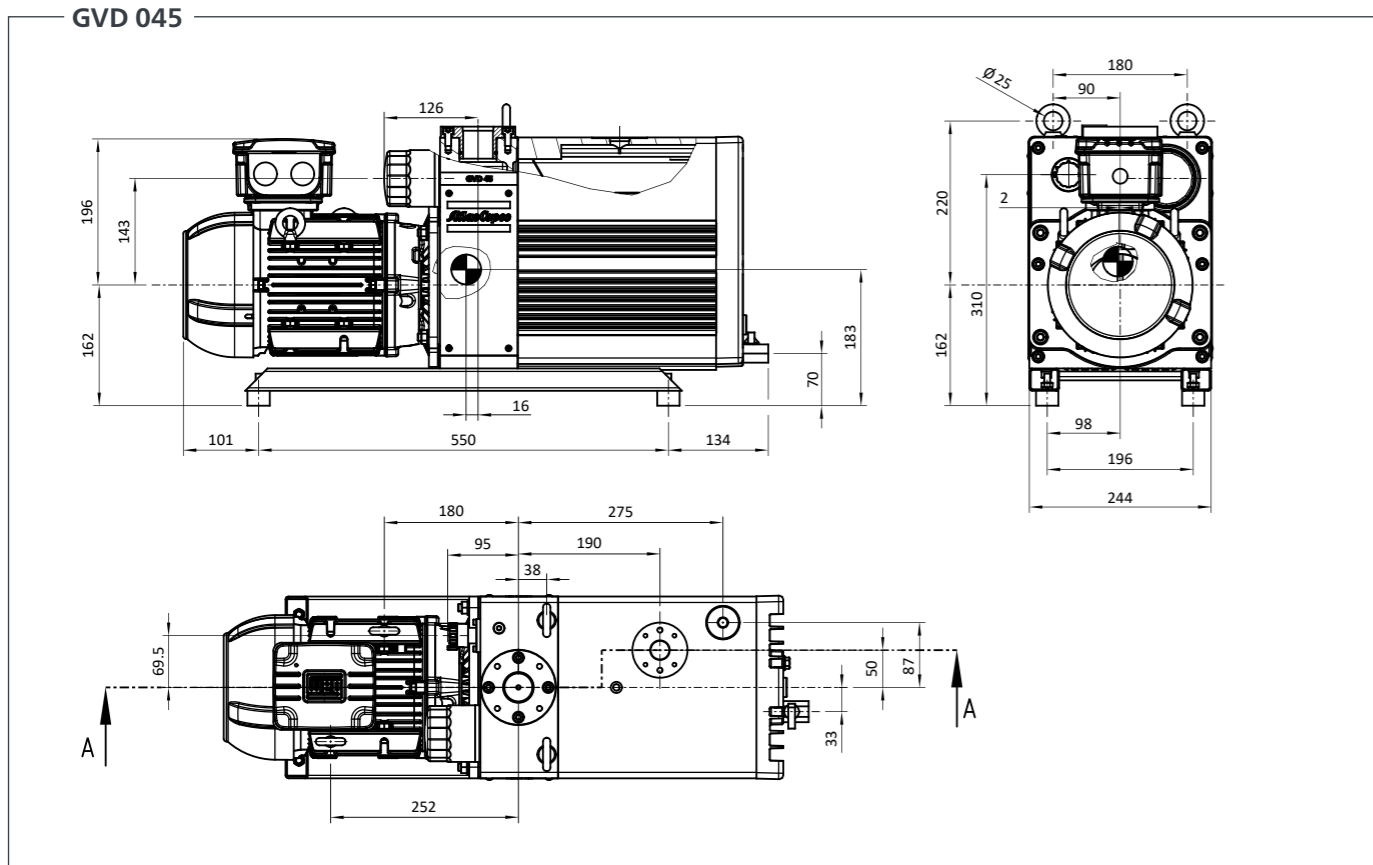

Service solutions Preventive care

Complete service with our Preventive Care plan



We take over the maintenance planning and responsibility for servicing your vacuum pump on a regular basis. Our Preventive Care plan is tailored to your pump's needs. As your pump is serviced with the latest technology, high levels of energy efficiency are achieved. We will also optimize service events to reduce your total cost of ownership and increase your productivity. This allows you to focus fully on your production.

Cost-effective approach



Regular scheduled maintenance can identify potential problems before they occur and plans can be structured around your individual production situation. Preventive Care enables cost management as you can plan your maintenance costs in advance. In this way, expenses associated with unplanned downtime are minimized.

Maximize the lifetime of your vacuum pumps



Our vacuum specialists are well trained and experts in the field. They will help you to improve uptime and protect your processes. Regular maintenance conducted by one of our vacuum specialists reduces the risk of deterioration. Damaged or worn parts will be replaced with genuine Atlas Copco spare parts to protect your investment and increase the lifespan of your vacuum pumps.

Reliability meets non-stop productivity



We use genuine Atlas Copco spare parts and oil and our services are conducted by vacuum specialists according to manufacturer's recommendations. This enhances your vacuum pump performance, reducing the risk of downtime and enabling your production to run more smoothly.



Atlas Copco AB
atlascopco.com/vacuum

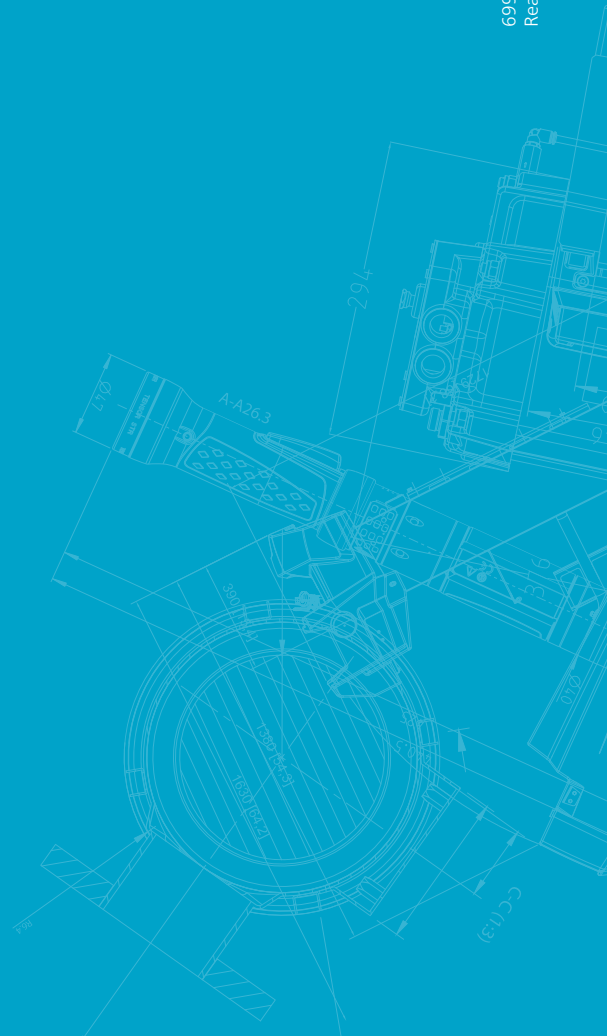

6996 0098 00 © 2023, Atlas Copco. All rights reserved. Designs and specifications are subject to change without notice or obligation. Read all safety instructions in the manual before usage.