

Atlas Copco



STRwrench

atlascopco.com

Tightening right the first time

In a production line, the quality of any critical joint can affect the entire product's safety. During the tightening process, several factors can result in safety-critical errors. Additionally, a single minute of a line stopped due to a safety-critical joint failure can cost up to 10,000 \$. That's why we are proud to introduce our new production tool: The STRwrench, enabling you to do the tightening right the first time.



Quality



Flexibility



Connectivity

High accuracy

The STRwrench has increased the torque range to 0.5% accuracy, giving full control of the torque operation. Thanks to the extended accuracy, the STRwrench now allows operators to perform the correct tightening first, avoiding the cost of re-work.

Accessibility & Ergonomics

The STRwrench offers a new approach to applications where accessibility and maneuverability are key. The optimized dimensions and the 90° rotational smartHEAD enable the operator to easily access even the most difficult joints.

Reliability

The STRwrench is easy to use and gives feedback to the operator, reducing the occurrence of errors. Vibration, LED strings, and sounds guide the user to a perfect tightening, according to the selected parameters and thresholds. This makes the STRwrench completely operator-independent.

Modularity & Durability

The new design of the STRwrench guarantees the hot-swap feature. The improved design concept and new materials make it possible to swap the smartHEAD without affecting the overall operability and durability. This drives an important optimization of the tools and time in the station.

Smart maintenance

The STRwrench provides real-time warnings and alarms in order to guide the user on the utilization and to avoid possible failures. Due to the new design, the smartHEAD can also be repaired and maintained, giving the STRwrench the possibility to easily change and revamp the different components.

Ease of use

The STRwrench, thanks to its new colored screen, is easier to use. All information is now clearly accessible by the operator on the new, clear, and robust screen. In addition, the STRwrench is designed to enable universal access through web browsers into the familiar Atlas Copco systems.



Join the Smart Factory revolution

The STRwrench consolidates Atlas Copco's factory digitalization. This is due to the transfer of data between the wrench components such as the controller, smartHEAD, and end-fittings, the improved memory that stores data, operations, and traces, and the complete connectivity offering. Furthermore, the STRwrench can be fully managed by the Integrated Controller without the need for any intermediate controller box. Thanks to those digital solutions, the STRwrench answers to all the Smart Factory user needs.



Torque accuracy range increased.
The STRwrench is now able to measure from 10% up to 100% of the nominal torque at 0.5% accuracy.



Improved feedback, LED signals, and a memory unit that is twice as big and saves all the relevant events and operations (up to 10,000 traces can be stored).



50.000 operations allowed, unlocking a real hot-swap feature maintaining the system on.



A new advanced concept on the battery, which now lasts 40% more and guarantees smart substitution.

Easy integration into the Atlas Copco Ecosystem

The STRwrench is fully integrated with Atlas Copco's Smart Connected Assembly ecosystem. It can easily be connected to any Power Focus controller to complete the range of assembly tools.

The Power Focus 6000 controller can manage five different types of tools that it controls with a common user interface, enabling all the possible needs of a station including programming, data collection, and even analysis.

Up to six tools can be connected to the same controller, optimizing the space. This, together with the STRwrench transducer hot-swap, means total flexibility for any kind of operation.

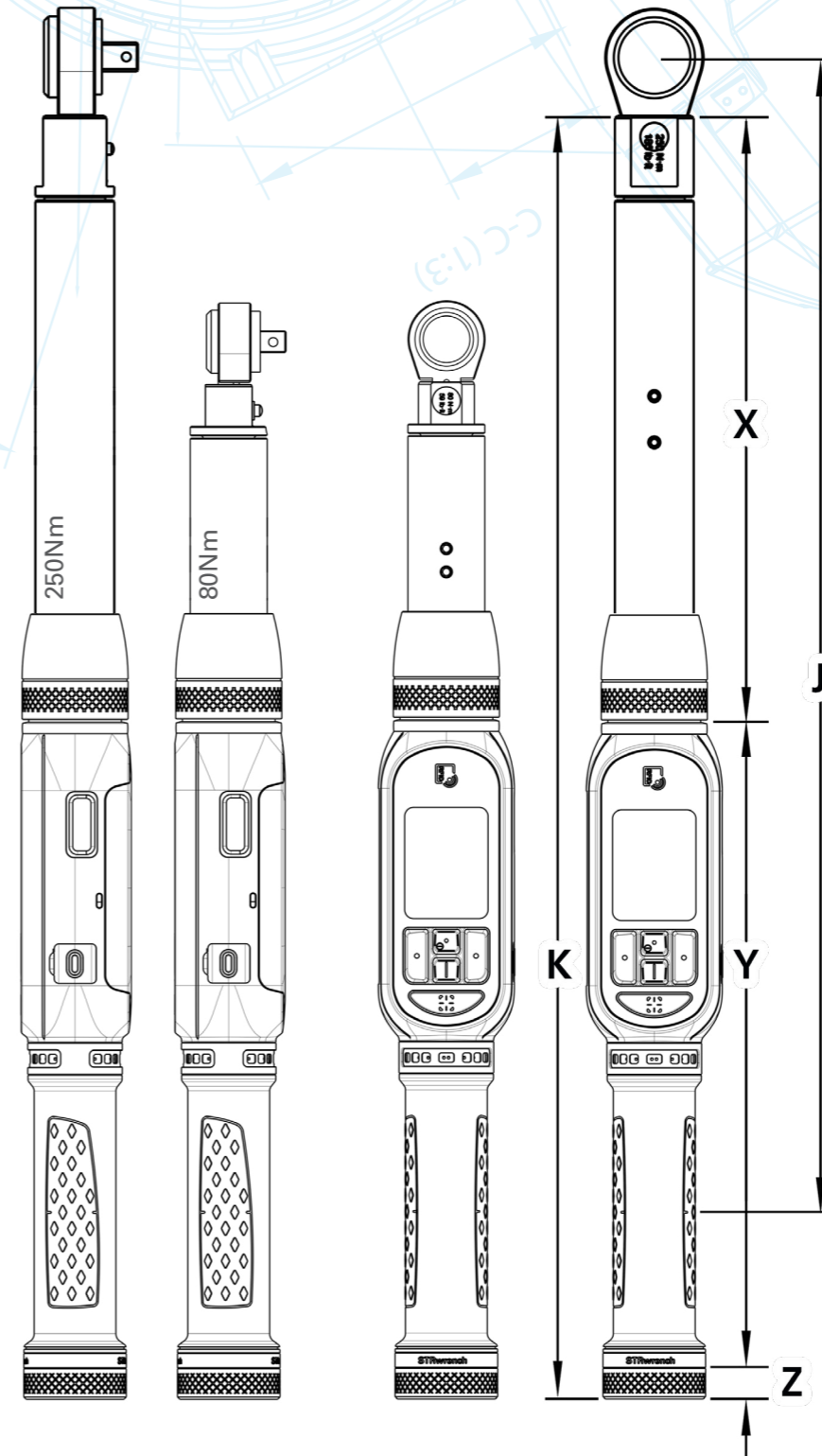
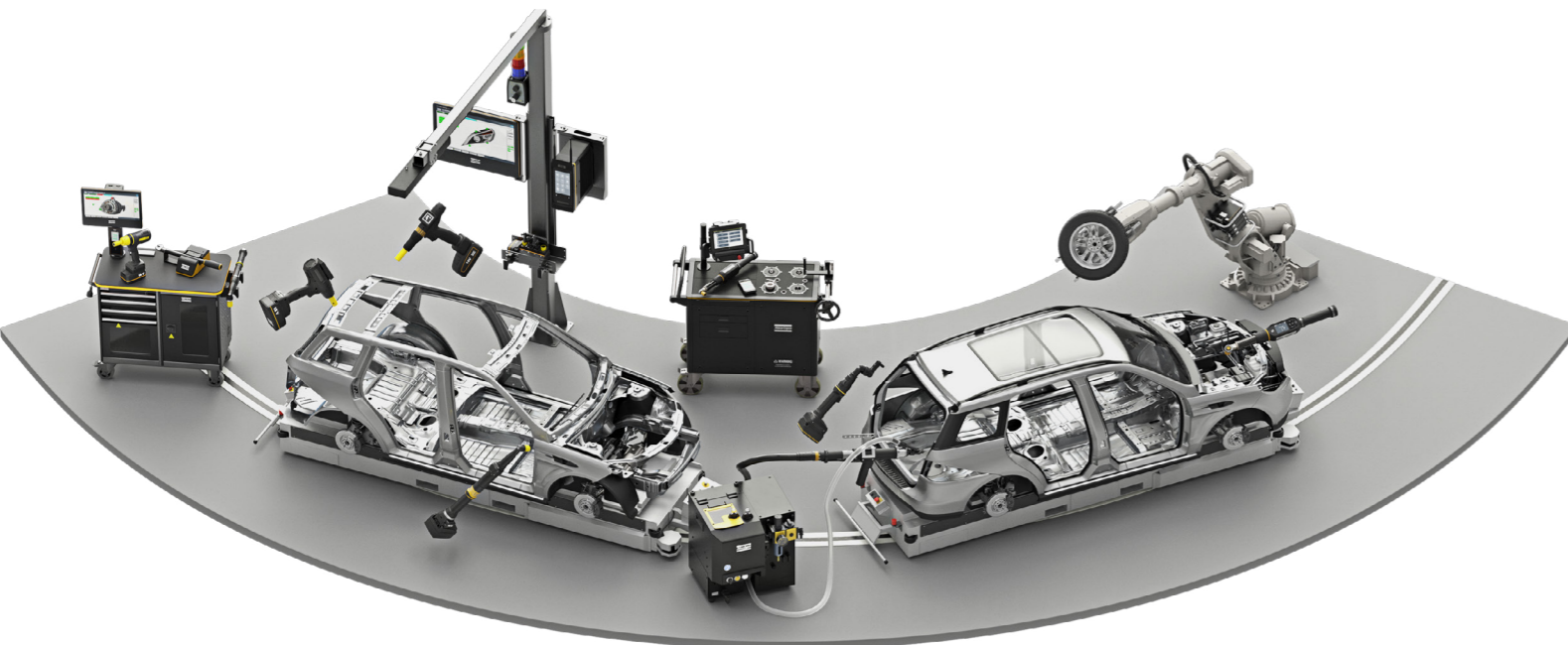
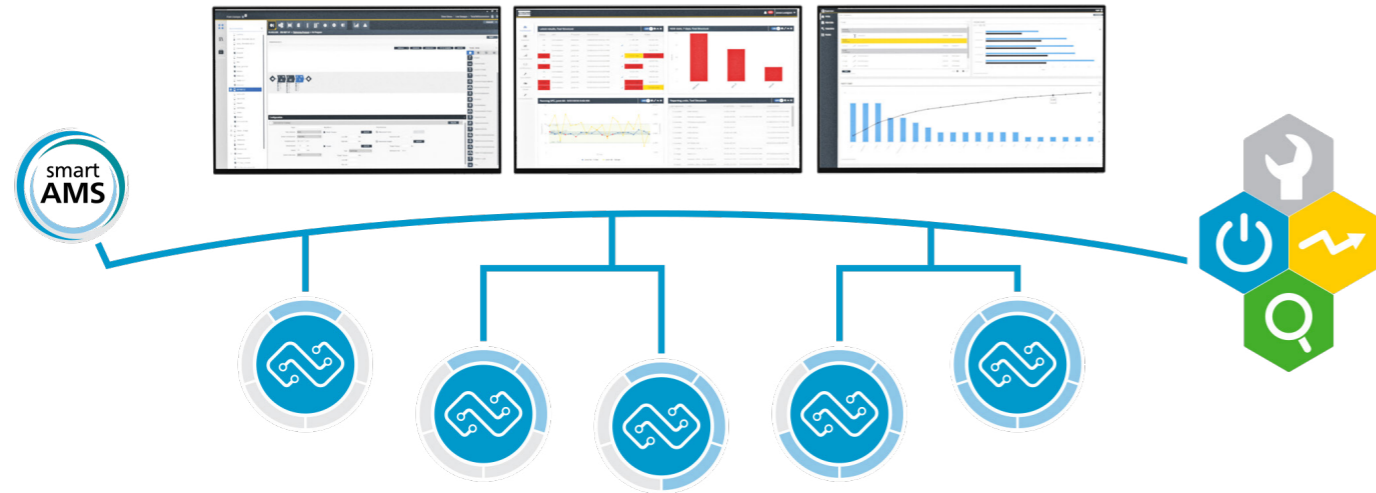

Model	Ordering Number
STRwrench	
Controller Compact	8059 0924 00
smartHEAD 80Nm	8059 0924 42
smartHEAD 250Nm	8059 0924 43
Battery	8059 0924 06
Battery charger	8059 0924 10

Model	J		K		X		Y		Z		E		Weight	
	mm	in	mm	in	mm	in	mm	in	mm	in	mm	in	Kg	lb
smartHEAD 80Nm	374,25	14,73	437	17,20	145	5,71	278,25	10,95	13,70	0,54	9x12	0,35x0,47	1,3 Kg	2,87
250Nm	499,15	19,65	554,1	21,81	262,15	10,32	278,25	10,95	13,70	0,54	14x18	0,55x0,71	1,7 Kg	3,75

See the STRwrench features and applications in virtual reality now! Download the app:





Atlas Copco Tools Central Europe GmbH

Langemarckstraße 35, D-45141 Essen
tools.de@atlascopco.com
www.atlascopco.com

